

# Part Diverting Systems Request Form — Part 1 of 2

## SPECIFY:

Please indicate dimensions in inches or feet  
(A = Operating Mold Open)

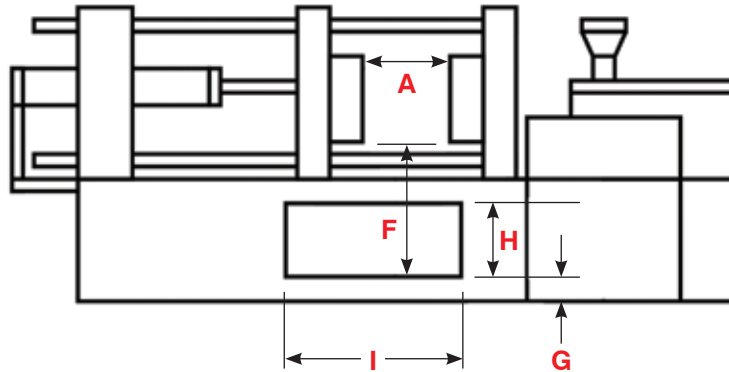
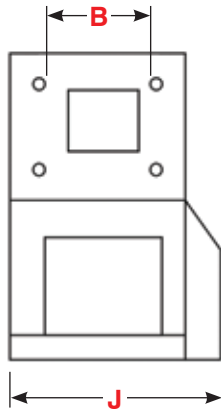

A: \_\_\_\_\_  
 B: \_\_\_\_\_  
 F: \_\_\_\_\_  
 G: \_\_\_\_\_  
 H: \_\_\_\_\_  
 I: \_\_\_\_\_  
 J: \_\_\_\_\_

## S1-Sorter

(shown with optional extensions and leg stand)



Will the S1-Sorter be discharging into a container?:  Yes  No

If Yes: Length: \_\_\_\_\_ Width: \_\_\_\_\_ Depth: \_\_\_\_\_

If No, than what?: \_\_\_\_\_

Are there any obstructions?:  Yes  No

If Yes: Length: \_\_\_\_\_ Width: \_\_\_\_\_ Depth: \_\_\_\_\_

Position: \_\_\_\_\_

## Optional Extensions

Desired extension length:

- 6"  12"  
 18"  Other \_\_\_\_\_"

(Custom charges may apply for lengths over 18")

No extensions desired

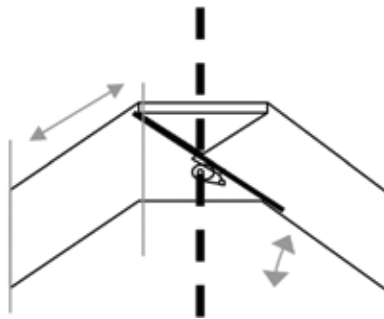

Desired angle:

- 25°  30° (Standard)  
 Other \_\_\_\_\_°

(Custom charges may apply for angles over 30°)

## Leg Stand

Required height from the floor:

- 7"  7" – 12"  
 12" – 20"  Other \_\_\_\_\_"

(Custom charges may apply for heights over 20")

No leg stand desired

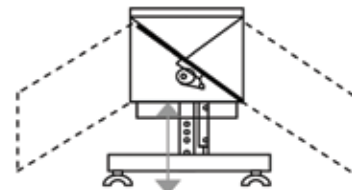

(Continued on next page)

# Part Diverting Systems Request Form — Part 2 of 2

## Optional Flared Top (Not available with Quick-Change Rail System — below)

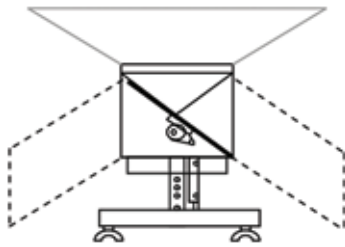

Desired Flare length:

A:  4"  6"  8" Other: \_\_\_\_\_

B:  4"  6"  8" Other: \_\_\_\_\_

(A & B are normally the same length)  
(custom charges may apply for lengths over 8")

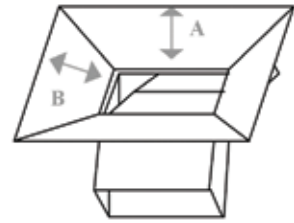

## Optional Quick-Change Rail System

(This system mounts to the press with our "Sliding Track System")

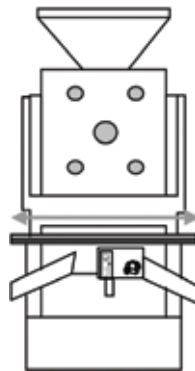
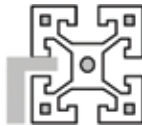

What is the depth of your press?:

Up to 36" deep

Up to 48" deep

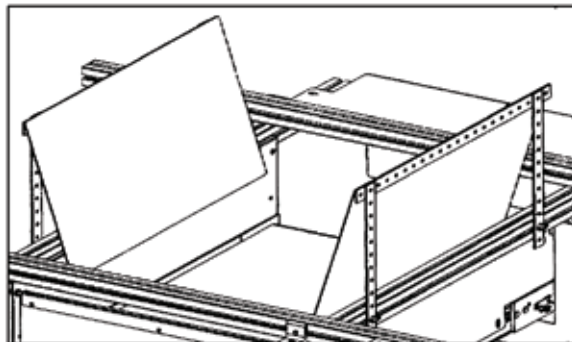
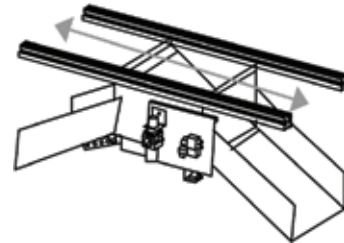

## Quick-Change Containment Package

These components are used to create custom part containment. This is designed for the end-user to cut to fit. Includes standard hardware.

Yes, please include this package on my quotation.

No, I am not interested in this optional package.

(Serves as a hopper for the QCRS System)

Date: \_\_\_\_\_ Quantity: \_\_\_\_\_ Phone: (\_\_\_\_\_) \_\_\_\_\_ Fax: (\_\_\_\_\_) \_\_\_\_\_

Name: \_\_\_\_\_ Title: \_\_\_\_\_

Company Name: \_\_\_\_\_ Email: \_\_\_\_\_

Address: \_\_\_\_\_

City: \_\_\_\_\_ State: \_\_\_\_\_ Zip: \_\_\_\_\_



[www.imscompany.com](http://www.imscompany.com)

phone order toll-free (USA & Canada) **1.800.537.5375**

fax order toll-free (USA & Canada)

phone order toll-free (Mexico)

tech support toll-free (USA & Canada)

e-mail

**1.888.288.6900**

**001.888.304.1307**

**1.866.467.9001**

**[sales@imscompany.com](mailto:sales@imscompany.com)**

Please refer to [imscompany.com](http://imscompany.com) for current pricing ©Copyright 2021 IMS Company. All rights reserved.